

2-needle, Needle-feed, Lockstitch Machine

LH-3128

LH-3128-7 (with automatic thread trimmer)

- The tension applied to the bobbin thread has been reduced and the needle thread path has been thoroughly renovated to achieve highly consistent feed of the needle thread. Puckering, stitch skipping, thread breakage and isolated idling loops can be therefore prevented, enabling the machine to produce beautifully finished seams with consistency.
- After the gauge has been replaced, the machine can be adapted to the newly installed gauge only by adjusting the clearance provided between the blade point of the hook and the needle. In this case, it is not necessary to change the hook timing in accordance with the gauge. As a result, the length of time required to replace the gauge is dramatically reduced.

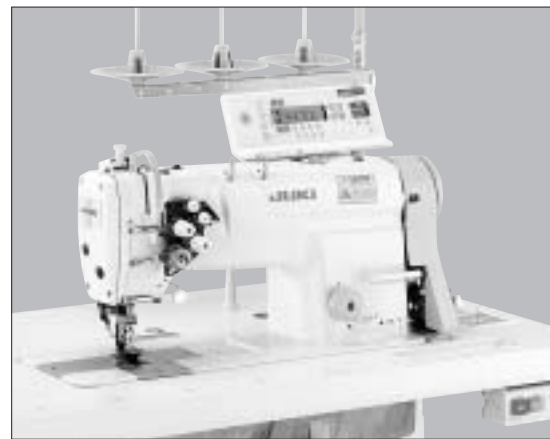

LH-3128-7-WB/CP-160B

2-needle, Needle-feed, Lockstitch Machine with Organized Split Needle Bar

LH-3168

LH-3168-7 (with automatic thread trimmer)

- The organized split needle bars which enable either the left or right needle to stop independently of the other can be changed over by simply operating the lever, thereby saving labor in corner stitching.



2-needle, Needle-feed, Lockstitch Machine with Large Hooks

LH-3178

LH-3178-7 (with automatic thread trimmer)

- Our investigation of the thread take-up stroke and other mechanisms results in the reduction of irregular stitches. Even at high speed, the machine performs sewing as consistently as the standard hook machine. The machine can make the most out of the advantageous features of the large hook, upgrading the finished quality of heavy-weight materials and improving efficiency.

2-needle, Needle-feed, Lockstitch Machine with Organized Split Needle Bar and Large Hooks

LH-3188

LH-3188-7 (with automatic thread trimmer)

- The organized split needle bar mechanism makes it possible to stop or reset the left or right needle by operating a one-touch utility lever.
- The machine produces neatly finished stitches at corner parts of the material.
- Improved thread tension and presser foot dramatically upgrades the seam adjusting ability. The range of thread counts that can be used is widened.

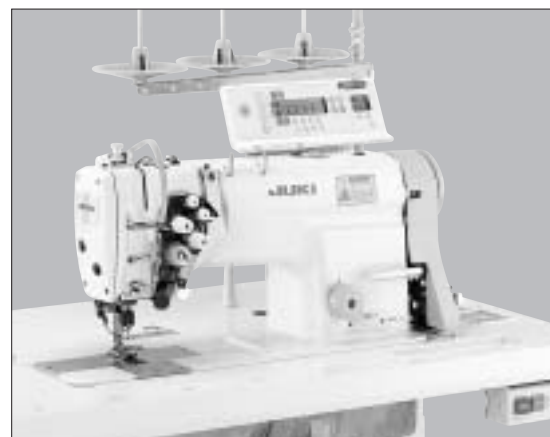

LH-3188-7-WB/CP-160B

2-needle, Bottom-feed, Lockstitch Machine

LH-3120

- The machine has adopted a bottom-feed mechanism. This enables the machine to perform sewing with a low tension applied to the material while preventing puckering and stitch skipping, thereby improving consistency of seam quality.
- The machine is capable of adapting to the sewing of light-weight materials and newly-developed materials. This means that the machine is exceedingly effective to the process to sew top center plaits of shirts and the sewing of foundation.



LH-3120

SPECIFICATIONS

● Without automatic thread trimmer

Model name	LH-3120A	LH-3128A	LH-3128S	LH-3128G
Feed system	Bottom-feed	Needle-feed		
Application	For light-weight materials	For light-weight materials	For medium-weight materials	For jeans and heavy-weight materials
Max. sewing speed	3,000rpm			
Max. stitch length	4mm (normal/reverse feed)	5mm (normal/reverse feed)		
Thread take-up	Slide type			
Needle bar stroke	33.4mm			
Lift of the presser foot	By hand: 5.5mm, By knee: 12mm			
Hook	Vertical-axis regular hook			
Needle (at the time of delivery)	DP x 5 (#9) #9 ~ #14	DP x 5 (#9) #9 ~ #14	DP x 5 (#14) #11 ~ #18	DP x 5 (#21) #18 ~ #22
Organized split needle bar mechanism	Not provided			
Lubrication	Fully automatic lubrication system by means of plunger pump			
Lubricating oil	JUKI New Defrix Oil No.2 (equivalent to ISO VG32)			
Distance from needle to machine arm	245mm			
Bed size	517mm x 178mm			
Weight of the machine head	38kg			

Model name	LH-3168A	LH-3168S	LH-3168G	LH-3178S	LH-3178G	LH-3188G
Feed system	Needle-feed					
Application	For light-weight materials	For medium-weight materials	For jeans and heavy-weight materials	For medium-weight materials	For jeans and heavy-weight materials	
Max. sewing speed	3,000rpm					
Max. stitch length	5mm (normal/reverse feed)					
Thread take-up	Slide type					
Needle bar stroke	33.4mm					
Lift of the presser foot	By hand: 5.5mm, By knee: 12mm					
Hook	Vertical-axis regular hook			Vertical-axis double-capacity hook		
Needle (at the time of delivery)	DP x 5 (#9) #9 ~ #14	DP x 5 (#14) #11 ~ #18	DP x 5 (#21) #18 ~ #22	DP x 5 (#14) #11 ~ #18	DP x 5 (#21) #18 ~ #22	
Organized split needle bar mechanism	Provided as standard			Not provided		Provided as standard
Lubrication	Fully automatic lubrication system by means of plunger pump					
Lubricating oil	JUKI New Defrix Oil No.2 (equivalent to ISO VG32)					
Distance from needle to machine arm	245mm					
Bed size	517mm x 178mm					
Weight of the machine head	38kg					

● With automatic thread trimmer

Model name	LH-3128A-7	LH-3128S-7	LH-3128G-7
Feed system	Needle-feed		
Application	For light-weight materials	For medium-weight materials	For jeans and heavy-weight materials
Max. sewing speed	3,000rpm		
Max. stitch length	5mm (normal/reverse feed)		
Thread take-up	Slide type		
Needle bar stroke	33.4mm		
Lift of the presser foot	By hand: 5.5mm, By knee: 12mm, By knee lifter with wiper: 9mm		
Hook	Vertical-axis regular hook		
Needle (at the time of delivery)	DP x 5 (#11) #11 ~ #14	DP x 5 (#14) #11 ~ #18	DP x 5 (#21) #18 ~ #22
Organized split needle bar mechanism	Not provided		
Lubrication	Fully automatic lubrication system by means of plunger pump		
Lubricating oil	JUKI New Defrix Oil No.2 (equivalent to ISO VG32)		
Distance from needle to machine arm	245mm		
Bed size	517mm x 178mm		
Weight of the machine head	43kg		
Power requirement Power consumption	Single-phase 100 ~ 120V, 200 ~ 240V, 3-phase 200 ~ 240V/650VA		

Model name	LH-3168A-7	LH-3168S-7	LH-3168G-7	LH-3178S-7	LH-3178G-7	LH-3188G-7
Feed system	Needle-feed					
Application	For light-weight materials	For medium-weight materials	For jeans and heavy-weight materials	For medium-weight materials	For jeans and heavy-weight materials	
Max. sewing speed	3,000rpm					
Max. stitch length	5mm (normal/reverse feed)					
Thread take-up	Slide type					
Needle bar stroke	33.4mm					
Lift of the presser foot	By hand: 5.5mm, By knee: 12mm, By knee lifter with wiper: 9mm					
Hook	Vertical-axis regular hook			Vertical-axis double-capacity hook		
Needle (at the time of delivery)	DP x 5 (#11) #11 ~ #14	DP x 5 (#14) #11 ~ #18	DP x 5 (#21) #18 ~ #22	DP x 5 (#14) #11 ~ #18	DP x 5 (#21) #18 ~ #22	DP x 5 (#21) #18 ~ #22
Organized split needle bar mechanism	Provided as standard			Not provided		Provided as standard
Lubrication	Fully automatic lubrication system by means of plunger pump					
Lubricating oil	JUKI New Defrix Oil No.2 (equivalent to ISO VG32)					
Automatic reverse feed function	Provided as standard					
Distance from needle to machine arm	245mm					
Bed size	517mm x 178mm					
Weight of the machine head	43kg					
Power requirement Power consumption	Single-phase 100 ~ 120V, 200 ~ 240V, 3-phase 200 ~ 240V/650VA					

WHEN YOU PLACE ORDERS

● With automatic thread trimmer

Type	Code
Needle-feed	28
Needle-feed with organized split needle bar	68
Needle-feed with large hooks	78
Needle-feed with organized split needle bar and large hooks	88

Application	Code
For light-weight materials	A
For medium-weight materials	S
For jeans and heavy-weight materials	G

Wiper and automatic reverse feed function		
Wiper	Automatic reverse feed function	Code
Not provided	Not provided	00
	Provided	0B
Provided	Not provided	W0
	Provided	WB

Auto-lifter	Code
Not provided	/
Pedal switch type (AK89)	89

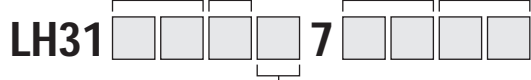

Code		A	B	C	D	E	F	G	H	K	W	L	M	N	P	Q	R	S
Needle gauge	mm	2.4	3.2	4.0	4.8	5.6	6.4	7.1	7.9	9.5	11.1	12.7	15.9	19.1	22.2	25.4	28.6	31.8
	inch	3/32	1/8	5/32	3/16	7/32	1/4	9/32	5/16	3/8	7/16	1/2	5/8	3/4	7/8	1	1-1/8	1-1/4
Model name	Spec.																	
LH-3128-7	A																	
	S																	
	G																	
LH-3168-7	A																	
	S																	
	G																	
LH-3178-7	S																	
	G																	
LH-3188-7	G																	

* Gauges marked () are standard type. Please contact us for any gauge which is not included in the above table.

● PSC box



Control box	Code
Standard	S

PSC box				Code
For JUS (LA)*	Single-phase	100 ~ 120V	PFL	S
For JUS*, General Export	3-phase	200 ~ 240V	PFL	D
For General Export	Single-phase	200 ~ 240V	PFL	K
For EU (CE)	Single-phase	200 ~ 240V	PFL	N
For China	Single-phase	200 ~ 240V	PFL	U

* JUS: North America and Central and South America.

● Motor for SC



Pulley belt	Code
Standard	S

● Operation panel

Operation panel	Code
IP-100B	IP100B
CP-160B	CP160B

● Without automatic thread trimmer

Type	Code
Bottom-feed	20
Needle-feed	28
Needle-feed with organized split needle bar	68
Needle-feed with large hooks	78
Needle-feed with organized split needle bar and large hooks	88

Application	Code
For light-weight materials	A
For medium-weight materials	S
For jeans and heavy-weight materials	G

LH31 



Code		A	B	C	D	E	F	G	H	K	W	L	M	N	P	Q	R	S	T	U		
Model name	Needle gauge	mm	2.4	3.2	4.0	4.8	5.6	6.4	7.1	7.9	9.5	11.1	12.7	15.9	19.1	22.2	25.4	28.6	31.8	34.9	38.1	
	Spec.	inch	3/32	1/8	5/32	3/16	7/32	1/4	9/32	5/16	3/8	7/16	1/2	5/8	3/4	7/8	1	1-1/8	1-1/4	1-3/8	1-1/2	
LH-3120	A																					
LH-3128	A																					
	S																					
	G																					
LH-3168	A																					
	S																					
	G																					
LH-3178	S																					
	G																					
LH-3188	G																					

* Gauges marked () are standard type. Please contact us for any gauge which is not included in the above table.

OPTIONS

Model	Part No.	Description	Feature
AK89		Auto-lifter	
V059	MAV-059000AA	Tension-free feeder (tape feeder)	The amount of tape to be fed can be adjusted in accordance with the sewing speed of the machine. It is adaptable to processes for attaching reinforcement tape, attaching elastic tape or lace to foundation.
AT-36		Tape cutter	The tape cutter is able to cut the tape just behind the presser foot (20mm away from the needle entry point). The cutter pressure is adjustable according to the material thickness.
	226-56854	Automatic reverse feed kit	The automatic reverse feed function device can be mounted on the machine after the setup. (*Synchronizer not included.)
	232-09059	Micro-lifter	This device can be installed on the back of the face plate. It is very convenient for frequent use.

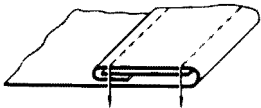
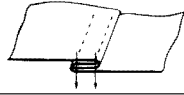
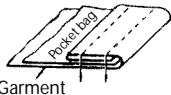
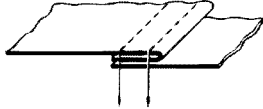
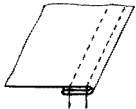
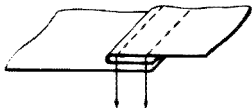
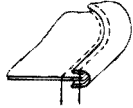
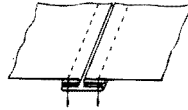
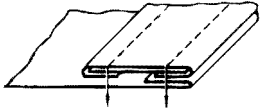
ATTACHMENTS

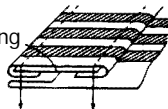
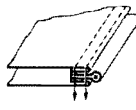
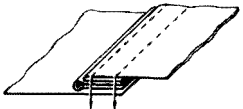
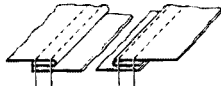
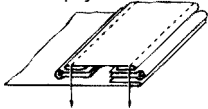
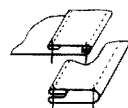
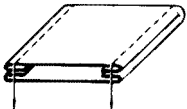
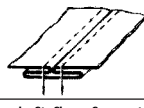
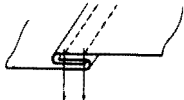
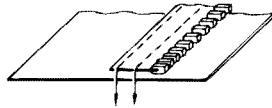
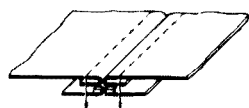
Name (Code No.)	Application and seam specifications	Applicable machines	Name (Code No.)	Application and seam specifications	Applicable machines
Top center plait hemmer (mousetrap latch type) (L030)	For making top center plait on men's shirts and hemming seats bed covers, etc. 	A type S type	Lapping seam folder (reverse) (M171)	For lapping seam in the various joining process including seaming sides of jeans, work uniforms, pantaloons etc. 	S type G type
Pocket hemmer sewing type (L032)	For hemming side pocket mouth of jeans, work uniforms etc. and hemming bottom of pants 	S type G type	Left feed top stitch folder (M024)	For seaming sides 	S type G type
Downturn hemmer (L045)	For sewing outside pocket mouth of jeans, work uniforms, etc. 	S type G type	Right feed top stitch folder (M025)	For seaming sides 	S type G type
Pocket binder (clean finish top and bottom) (N054)	To tape attaching process to bind edges of pocket bags of slacks, pants, skirts, etc. 	S type	Tape attaching foot with center guide (B006)	For opening seam of brassieres, body suits etc. 	LH-3128F A type S type
Top center plait (folder) (M315)	For attaching formal top center plait on men's shirts, etc. 	A type S type	Sewing edge guide (H010)	Edge guide applicable to runstitching process and decorative stitching process 	S type G type
Center plait folder (from neck down) (M037)	For making front facing from the neck side. Interlining 	A type S type	Sewing roller guide (H011)	Edge guide for runstitch process using vinylcoated cloth or man-made leather. 	S type G type
Right feed piping folder (M137)	To the process for sewing decorative pipings on sports wear, work uniforms, etc. 	S type G type	Presser foot with guide (B009)	Lapping seam process and counterstitching process for denim, drill, wool, gabardine, etc. 	S type G type
Pajama piping folder (M163)	For sewing pipings on the edges of pockets, top-center plaits, bottoms, sleeves, etc. of pajamas. 	A type S type	Compensating presser foot (B020)	For making top center plaits of knit shirts, blouses, etc. and for making belts of ladies' wear 	S type G type
Belt folder (turnable mousetrap latch type) (N012)	For making belts including shoulder straps of children's rompers, belts of ladies' overcoats etc. 	S type G type	Box pleats folder (small type) (M009)	For sewing box pleats of skirts, box pleats at the back center of ladies' overcoats, sewing box pleats of office uniforms, work uniforms, etc. 	LH-3128
Lapping seam folder (M170)	For lapping seam in the various joining process including joining sides of jeans, work uniforms, pantaloons etc. 	S type G type	Zipper guide (Q090)	For runstitching left fly of pants and zippers 	S type
			Zipper folder (S004B)	Attaching zippers on skirts, jumpers, matcovers, etc. 	LH-3128S

* The part numbers are designated according to needle gauge and specification.
Be sure to confirm the part number of the attachment you need when placing your order with us.

TABLE OF EXCHANGE PARTS FOR LH3100 SERIES

LH-3128



Needle gauge size		Throat plate	Feed dog			Presser foot asm.		
Code								(tipdivided)
A	2.4mm (3/32")	226-25008	226-35007			226-37557		
B	3.2mm (1/8")	226-25107	226-30107			226-37656		
C	4.0mm (5/32")	226-25206	226-35205	226-30206		226-37755	101-52650	
D	4.8mm (3/16")	226-25305	226-35304	226-30404	B1613-512-DOH	226-37854	101-52759	226-40353
E	5.6mm (7/32")	226-25404	226-35403	226-30503	B1613-512-EOH	226-37953	101-52858	226-40452
F	6.4mm (1/4")	226-25503	226-35502	226-30602	B1613-512-FOH	226-38050	101-52957	226-40551
G	7.1mm (9/32")	226-25602	226-35700	226-30800	B1613-512-GOH	226-38258	101-53054	226-40759
H	7.9mm (5/16")	226-25701	226-35809	226-30909	B1613-512-HOH	226-38357	101-53153	226-40858
K	9.5mm (3/8")	226-25800	226-35908	226-31006	B1613-512-KOH	226-38456	101-53252	226-40957
W	11.1mm (7/16")	226-25909	226-36005	226-31105	*	226-38555	101-53351	226-41054
L	12.7mm (1/2")	226-26006	226-36203	226-31303	B1613-512-LOH	226-38753	101-53450	226-41252
M	15.9mm (5/8")	226-26105	226-36302	226-31402	B1613-512-MOH	226-38852	101-53559	226-41351
N	19.1mm (3/4")	226-26204	226-36401	226-31501	B1613-512-NOH	226-38951	101-53658	226-41450
P	22.2mm (7/8")	226-26303	226-36609	226-31709	B1613-512-POH	226-39157	101-53757	226-41658
Q	25.4mm (1")	226-26402	226-36708	226-31808	B1613-512-QOH	226-39256	101-53856	226-41757
R	28.6mm (1-1/8")	226-26501	226-36807	226-31907	B1613-512-ROH	226-39355	101-53955	226-41856
S	31.8mm (1-1/4")	226-26600	226-36906	226-32004	B1613-512-SOH	226-39454	101-54052	226-41955
T	34.9mm (1-3/8")	226-26709	226-37003	226-32103	B1613-512-TOH	226-39553	101-54151	226-42052
U	38.1mm (1-1/2")	226-26808	226-37102	226-32202	B1613-512-UOH	226-39652	101-54250	226-42151
Stitch spec.	S	Spec. common						
	A							
	G							

LH-3128-7

Needle gauge size		Throat plate with thread trimmer	Feed dog (with thread trimmer)			Needle clamp asm.
Code						
A	2.4mm (3/32")	226-60104	226-65004			101-47551
B	3.2mm (1/8")	226-60203	226-65103			101-47650
C	4.0mm (5/32")	226-60302	226-65202	102-37907		101-47759
D	4.8mm (3/16")	226-60401	226-65301	102-38004	102-39101	101-47858
E	5.6mm (7/32")	226-60500	226-65440	102-38103	102-39200	101-47957
F	6.4mm (1/4")	226-60609	226-65509	102-38202	102-39309	101-48054
G	7.1mm (9/32")	226-60708	226-65707	102-38301	102-39408	101-48153
H	7.9mm (5/16")	226-60807	226-65806	102-38400	102-39507	101-48252
K	9.5mm (3/8")	226-60906	226-65905	102-38509	102-39606	101-48351
W	11.1mm (7/16")	226-61003	226-66002	101-68300	101-70801	101-48450
L	12.7mm (1/2")	226-61102	226-66200	102-38707	102-39804	101-48559
M	15.9mm (5/8")	226-61201	226-66309	102-38806	102-39903	101-48658
N	19.1mm (3/4")	226-61300	226-66408	102-38905	101-71106	101-48757
P	22.2mm (7/8")	226-61409	226-66606	102-68706	101-71205	101-48856
Q	25.4mm (1")	226-61508	226-66708	102-39002	101-71304	101-48955
R	28.6mm (1-1/8")	226-61607	226-66804	101-68904	101-71403	101-49052
S	31.8mm (1-1/4")	226-61706	226-66903	101-69001	101-71502	101-49151
T	34.9mm (1-3/8")					101-49250
U	38.1mm (1-1/2")					101-49359
Stitch spec.	S	Spec. common				Spec. common
	A					
	G					



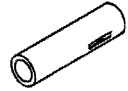
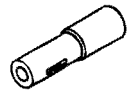

Standard spec.
Substandard spec.
* Special order

LH-3128/3128-7





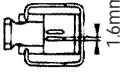
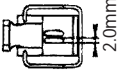
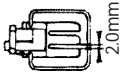

Needle gauge size		Bed slide asm. (with thread trimmer)	
Code		Bed Slide asm. (left) 	Bed Slide asm. (right) 
A W	2.4mm (3/32") 11.4mm (7/16")	226-50857	226-50352
L N	12.7mm (1/2") 19.1mm (3/4")	226-50956	226-50451
P Q	22.2mm (7/8") 28.6mm (1-1/8")	226-51053	226-50550
S U	31.8mm (1-1/4") 38.1mm (1-1/2")	226-51152	226-50659

Needle gauge size		Front metal	Inner metal
Code			
A P	2.4mm (3/32") 22.2mm (7/8")	B1802-512-0A0A	B1803-515-0A0
Q U	25.4mm (1") 38.1mm (1-1/2")	B1802-512-0AB	101-12357



LH-3168

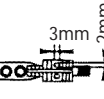

Needle gauge size		Throat plate	Feed dog			Presser foot asm.		
Code								
B	3.2mm (1/8")	226-25107	226-30107			226-37656		
C	4.0mm (5/32")	226-25206	226-35205	226-30206		226-37755	101-52650	
D	4.8mm (3/16")	226-25305	226-35304	226-30404	B1613-512-DOH	226-37854	101-52759	226-40353
E	5.6mm (7/32")	226-25404	226-35403	226-30503	B1613-512-EOH	226-37953	101-52858	226-40452
F	6.4mm (1/4")	226-25503	226-35502	226-30602	B1613-512-FOH	226-38050	101-52957	226-40551
G	7.1mm (9/32")	226-25602	226-35700	226-30800	B1613-512-GOH	226-38258	101-53054	226-40759
H	7.9mm (5/16")	226-25701	226-35809	226-30909	B1613-512-HOH	226-38357	101-53153	226-40858
K	9.5mm (3/8")	226-25800	226-35908	226-31006	B1613-512-KOH	226-38456	101-53252	226-40957
L	12.7mm (1/2")	226-26006	226-36203	226-31303	B1613-512-LOH	226-38753	101-53450	226-41252
M	15.9mm (5/8")	226-26105	226-36302	226-31402	B1613-512-MOH	226-38852	101-53559	226-41351
N	19.1mm (3/4")	226-26204	226-36401	226-31501	B1613-512-NOH	226-38951	101-53658	226-41450
Q	25.4mm (1")	226-26402	226-36708	226-31808	B1613-512-QOH	226-39256	101-53856	226-41757
Stitch spec.	S	Spec. common						*
	A							
	G						*	

LH-3168-7

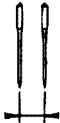



Needle gauge size		Throat plate with thread trimmer	Feed dog (with thread trimmer)			Needle clamp asm. Left	Needle clamp asm. Right	
Code								
B	3.2mm (1/8")	226-60203	226-65103			B1402-528-BA0A	B1402-528-BA0A	Standard spec.
C	4.0mm (5/32")	226-60302	226-65202	102-37907		B1402-528-CA0A	B1402-528-CA0A	Substandard spec.
D	4.8mm (3/16")	226-60401	226-65301	102-38004	102-39101	B1402-528-DALA	B1402-528-DARA	* Special order
E	5.6mm (7/32")	226-60500	226-65400	102-38103	102-39200	B1402-528-EAL	B1402-528-EAR	
F	6.4mm (1/4")	226-60609	226-65509	102-38202	102-39309	B1402-528-FAL	B1402-528-FAR	
G	7.1mm (9/32")	226-60708	226-65707	102-38301	102-39408	B1402-528-GAL	B1402-528-GAR	
H	7.9mm (5/16")	226-60807	226-65806	102-38400	102-39507	B1402-528-HALA	B1402-528-HARA	
K	9.5mm (3/8")	226-60906	226-65905	102-38509	102-39606	B1402-528-KALA	B1402-528-KARA	
L	12.7mm (1/2")	226-61102	226-66200	102-38707	102-39804	B1402-528-LAL	B1402-528-LAR	
M	15.9mm (5/8")	226-61201	226-66309	102-38806	102-39903	B1402-528-MAL	B1402-528-MAR	
N	19.1mm (3/4")	226-61300	226-66408	102-38905	101-71106	B1402-528-NAL	B1402-528-NAR	
Q	25.4mm (1")	226-61508	226-66705	102-39002	101-71304	B1402-528-QAL	B1402-528-QAR	
Stitch spec.	S	Spec. common				Spec. common		
	A					Spec. common		
	G					Spec. common		

LH-3168/LH-3168-7



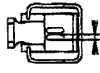
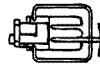

Needle gauge size	Bed slide asm. (with thread trimmer)		
	Bed slide asm. (left)	Bed slide asm. (right)	
Code			
B	3.2mm (1/8")	226-50857	226-50352
K	9.5mm (3/8")		
L	12.7mm (1/2")	226-50956	226-50451
N	19.1mm (3/4")		
Q	25.4mm (1")	226-51053	226-50550

Needle gauge size	Front metal	Inner metal	
Code			
B	1/8" (3.2mm)	B1802-512-0A0A	B1803-515-0A0
N	3/4" (19.1mm)		
Q	1" (25.4mm)	B1802-512-0AB	101-12357

LH-3178

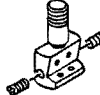
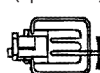

Needle gauge size		Throat plate	Feed dog		Presser foot asm.	
Code			 1.9	 2.4 * 2.2	 2.0mm	 2.4mm (tipdivided)
A	2.4mm (3/32")					
B	3.2mm (1/8")	226-25107	226-30107		226-37657	
C	4.0mm (5/32")	226-25206	226-30206		101-52650	
D	4.8mm (3/16")	226-25305	226-30404	228-15401	101-52759	228-16557
E	5.6mm (7/32")	226-25404	226-30503	228-15500	101-52858	228-16656
F	6.4mm (1/4")	226-25503	226-30602	228-15609	101-52957	228-16755
G	7.1mm (9/32")	226-25602	226-30800	228-15708	101-53054	228-16854
H	7.9mm (5/16")	226-25701	226-30909	228-15807	101-53153	228-16953
K	9.5mm (3/8")	226-25800	226-31006	228-15906	101-53252	228-17050
W	11.1mm (7/16")	226-25909	226-31105		101-53351	
L	12.7mm (1/2")	226-26006	226-31303	228-16003	101-53450	228-17159
M	15.9mm (5/8")	226-26105	226-31402		101-53559	
N	19.1mm (3/4")	226-26204	226-31501		101-53658	
P	22.2mm (7/8")	226-26303	226-31709		101-53757	
Q	25.4mm (1")	226-26402	226-31808	*B1613-512-Q0H	101-53856	226-41757
R	28.6mm (1-1/8")	226-26501	226-31907	*B1613-512-R0H	101-53955	226-41856
S	31.8mm (1-1/4")	226-26600	226-32004	*B1613-512-S0H	101-54052	226-41955
T	34.9mm (1-3/8")	226-26709	226-32103	*B1613-512-T0H	101-54151	226-42052
U	38.1mm (1-1/2")	226-26808	226-32202	*B1613-512-U0H	101-54250	226-42151
Stitch spec.	S	Spec. common				
	G					

LH-3178-7

Needle gauge size		Throat plate with thread trimmer	Feed dog (with thread trimmer)		Needle clamp asm.	Presser foot asm.
Code			 2.0	 2.4		 2.0mm (tipdivided)
A	2.4mm (3/32")					
B	3.2mm (1/8")	226-60203	226-65103		101-47650	102-22255
C	4.0mm (5/32")	226-60302	102-37907		101-47759	102-22354
D	4.8mm (3/16")	226-60401	102-38004	228-21201	101-47858	226-40353
E	5.6mm (7/32")	226-60500	102-38103	228-21300	101-47957	226-40452
F	6.4mm (1/4")	226-60609	102-38202	228-21409	101-48054	226-40551
G	7.1mm (9/32")	226-60708	102-38301	228-21508	101-48153	226-40759
H	7.9mm (5/16")	226-60807	102-38400	228-21607	101-48252	226-40858
K	9.5mm (3/8")	226-60906	102-38509	228-21706	101-48351	226-40957
W	11.1mm (7/16")	226-61003	101-68300		101-48450	
L	12.7mm (1/2")	226-61102	101-38707	228-21805	101-48559	226-41252
M	15.9mm (5/8")	226-61201	102-38806		101-48658	226-41351
N	19.1mm (3/4")	226-61300	102-38905		101-48757	226-41450
P	22.2mm (7/8")	226-61409	101-68706		101-48856	
Q	25.4mm (1")	226-61508	102-39002		101-48955	226-41757
R	28.6mm (1-1/8")	226-61607	101-68904		101-49052	
S	31.8mm (1-1/4")	226-61706	101-69001		101-49151	
T	34.9mm (1-3/8")				101-49250	
U	38.1mm (1-1/2")				101-49359	
Stitch spec.	S	Spec. common			Spec. common	
	G					





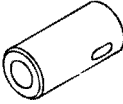
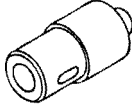

Standard spec.

LH-3178/3178-7



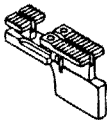

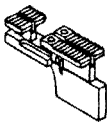
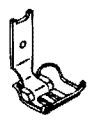
Needle gauge size		Bed slide asm. (with thread trimmer)	
Code		Bed slide asm. (left) 	Bed slide asm. (right) 
A W	2.4mm (3/32") 11.4mm (7/16")	226-50857	226-50352
L N	12.7mm (1/2") 19.1mm (3/4")	226-50956	226-50451
P Q	22.2mm (7/8") 28.6mm (1-1/8")	226-51053	226-50550
S U	31.8mm (1-1/4") 38.1mm (1-1/2")	226-51152	226-50659

Needle gauge size		Front metal	Inner metal
Code			
A P	2.4mm (3/32") 22.2mm (7/8")	B1802-512-0A0A	B1803-515-0A0
Q U	25.4mm (1") 38.1mm (1-1/2")	B1802-512-0AB	101-12357





● Chain-off thread gauge

Needle gauge size	Throat plate (with- out thread trimmer)	Feed dog (without thread trimmer)	Throat plate (with thread trimmer)	Feed dog (with thread trimmer)	Presser foot asm.	Feed dog screw	
Code							
D	4.8mm (3/16")	228-35003	228-35557	228-35201	106-91053	B1524-512-DBH	SS6580710TP × 2
F	6.4mm (1/4")	228-35102	228-35656	228-35300	106-98652	B1524-512-FBE	



LH-3188

Needle gauge size		Throat plate	Feed dog	Presser foot asm.
Code				(tipdivided) 
B	3.2mm (1/8")			
C	4.0mm (5/32")			
D	4.8mm (3/16")	226-25305	228-15401	228-16557
E	5.6mm (7/32")	226-25404	228-15500	228-16656
F	6.4mm (1/4")	226-25503	228-15609	228-16755
G	7.1mm (9/32")	226-25602	228-15708	228-16854
H	7.9mm (5/16")	226-25701	228-15807	228-16953
K	9.5mm (3/8")	226-25800	228-15906	228-17050
L	12.7mm (1/2")	226-26006	228-16003	228-17159
M	15.9mm (5/8")			
N	19.1mm (3/4")			
Q	25.4mm (1")			
Stitch spec.	S	Spec. common		
	A			
	G			

LH-3188-7





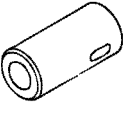
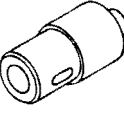

Needle gauge size		Throat plate with thread trimmer	Feed dog (with thread trimmer)	Needle clamp asm. Left	Needle clamp asm. Right
Code					
B	3.2mm (1/8")				
C	4.0mm (5/32")				
D	4.8mm (3/16")	226-60401	228-21201	B1402-528-DALA	B1402-528-DARA
E	5.6mm (7/32")	226-60500	228-21300	B1402-528-EAL	B1402-528-EAR
F	6.4mm (1/4")	226-60609	228-21409	B1402-528-FALA	B1402-528-FARA
G	7.1mm (9/32")	226-60708	228-21508	B1402-528-GAL	B1402-528-GAR
H	7.9mm (5/16")	226-60807	228-21607	B1402-528-HALA	B1402-528-HARA
K	9.5mm (3/8")	226-60906	228-21706	B1402-528-KALA	B1402-528-KARA
L	12.7mm (1/2")	226-61102	228-21805	B1402-528-LAL	B1402-528-LAR
M	15.9mm (5/8")				
N	19.1mm (3/4")				
Q	25.4mm (1")				
Stitch spec.	S	Spec. common		Spec. common	
	A				
	G				

LH-3188/3188-7



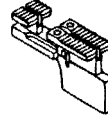

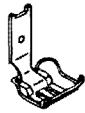

Needle gauge size		Bed slide asm. (with thread trimmer)	
Code		Bed slide asm. (left) 	Bed slide asm. (right) 
B	3.2mm (1/8")	226-50857	226-50352
K	9.5mm (3/8")		
L	12.7mm (1/2")	226-50956	226-50451
N	19.1mm (3/4")		
Q	25.4mm (1")	226-51053	226-50550

Needle gauge size		Front metal	Inner metal
Code			
A	2.4mm (3/32")	B1802-512-0A0A	B1803-515-0A0
P	22.2mm (7/8")		
Q	25.4mm (1")	B1802-512-0A0B	101-12357
U	38.1mm (1-1/2")		



● Chain-off thread gauge

Needle gauge size	Throat plate (without thread trimmer)	Feed dog (without thread trimmer)	Throat plate (with thread trimmer)	Feed dog (with thread trimmer)	Presser foot asm.	Feed dog screw
Code						
D	4.8mm (3/16")	228-35003	228-35557	228-35201	B1524-512-DBH	SS6580710TP × 2
F	6.4mm (1/4")	228-35102	228-35656	228-35300	B1524-512-FBE	

LH-3120

Needle gauge size		Throat plate		Feed dog		Presser foot asm.	Needle clamp asm.
Code							
A	2.4mm (3/32")						
B	3.2mm (1/8")	228-45200		228-47206		103-91852	101-47650
C	4.0mm (5/32")						
D	4.8mm (3/16")	228-45408		228-47404		103-92058	101-47858
E	5.6mm (7/32")						
F	6.4mm (1/4")	228-45606		228-47602		103-92256	101-48054
G	7.1mm (9/32")						
H	7.9mm (5/16")						
K	9.5mm (3/8")						
W	11.1mm (7/16")						
L	12.7mm (1/2")		228-46109		228-48105	103-92751	101-48559
M	15.9mm (5/8")						
N	19.1mm (3/4")		228-46307		228-48303	103-93056	101-48757
P	22.2mm (7/8")		228-46406		228-48402	228-44450	101-48856
Q	25.4mm (1")		228-46505		228-48501	228-44559	101-48955
R	28.6mm (1-1/8")						
S	31.8mm (1-1/4")						
T	34.9mm (1-3/8")						
U	38.1mm (1-1/2")						
Stitch spec.	A					Spec. common	Spec. common

LH-3120

Needle gauge size		Bed slide asm. (with thread trimmer)	
Code		Bed slide asm. (left) 	Bed slide asm. (right) 
A	2.4mm (3/32")		
W	11.4mm (7/16")	226-50857	226-50352
L	12.7mm (1/2")		
N	19.1mm (3/4")	226-50956	226-50451
P	22.2mm (7/8")		
Q	28.6mm (1-1/8")	226-51053	226-50550

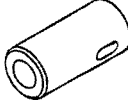
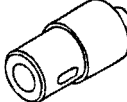
Needle gauge size		Front metal	Inner metal
Code			
A	2.4mm (3/32")		
P	22.2mm (7/8")	B1802-512-0A0A	B1803-515-0A0
Q	25.4mm (1")		
U	38.1mm (1-1/2")	B1802-512-0AB	101-12357